

Level switch Vibrating fork system

Serie LD60/LD61



Level Switch for Solids and Liquids Vibrating Fork System

Working pressure manufacturing according to PED 97/23/CE (Lloyd's Register Certificate N° 031)

Introduction

The LD60/LD61 is a level switch using the vibrating fork technique.

It is a robust and compact switch for the measurement of liquids and solids (only LD60). Some typical applications are:

- Pump control
- Tanks open and pressurized
- Tanks with agitation
- Open channel and pipe empty/full detection
- Distillation columns
- Evaporators
- Chemical dosing tanks

Benefits

- No moving parts
- Not affected by temperatures or pressure changes
- Suitable for liquids with viscosity up to 10,000 cSt.
- Minimum density 0.6 kg/l
- Detection of solids (powders) only LD60
- Corrosion resistant materials
- Maintenance free
- Integral electronics
- Selection of normally open or normally closed operation
- LED status indication (bicolor)
- Functions test with external magnet
- Connections:
 - Thread: BSP / NPT
 - Flange: DIN / ANSI
 - Sanitary: Clamp, Naue, DIN 11851
- Wide range of sensor lengths





Principle of Operation

The Series LD60/LD61 is a level switch using the vibrating fork technique. An electronically controlled piezo-electric system vibrates the fork at its natural frequency.

The change of frequency in the presence of a liquid, or of the amplitude in the presence of a solid, is detected and controls the change in the state of the output switch.

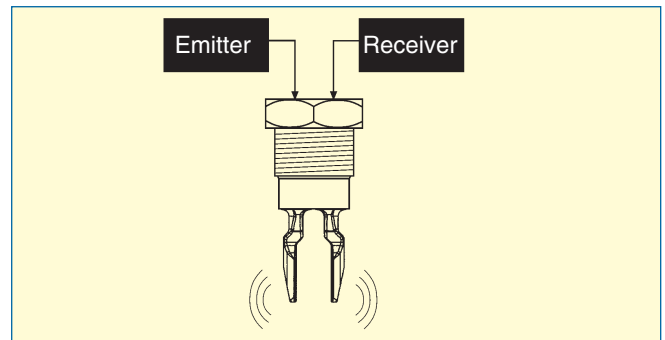

Technical Data

- Hysteresis: ± 2 mm (H₂O)
- Reponse Time: > 1 seg
- Viscosity up to 10.000 cSt.
- Minimum density 0,6 kg/l
- Materials: Body EN 1.4404 (SS 316L)
- Enclosure: Polycarbonate
- Connections: 1" Thread GAS/NPT (other on demand)
- Temperature Limits: Ambient - 20°C to +70°C Fluid Temp -30°C +115°C
- Working pressure manufacturing according to PED 97/23/CE (Lloyd's Register Certificate N° 031)
- Pressure Limits: Thread (BSP/NPT) 16 bar Flange (DIN, ANSI, JIS) PN-16...PN-100 On request up to 400 bar
- Power Supply: 2 wires: 24...250 V ac. Load (max) 350 mA 3 wires: 10.....55 V dc. Load (max) 350 mA
- Load: 6 mA at rest

- Status indication by 2 colour LED
- Connections: IP 65 DIN 43650-A
- Sensor length: 70 to 6,000 mm Others on request

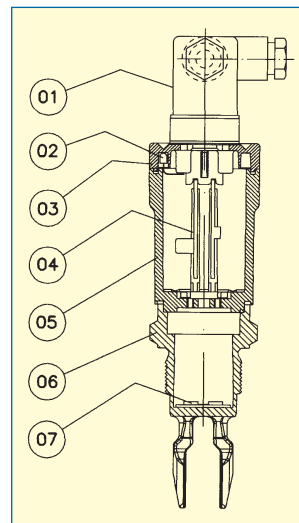

Part list

N°	Part	Material
01	connector	plastic
02	LED	plastic
03	cover	polycarbonate
04	electronics	-
05	enclosure	polycarbonate
06	body	EN 1.4404 (SS 316L)
07	transducer	ceramic

Graph 1

T1 / T2

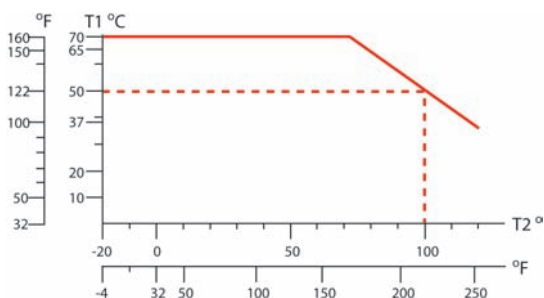

Graph 1

The maximum working temperature of the inside of the tank (T2) is a function of the ambient temperature on the outside, as shown in graph 1.

Graph 2

P1 / T2

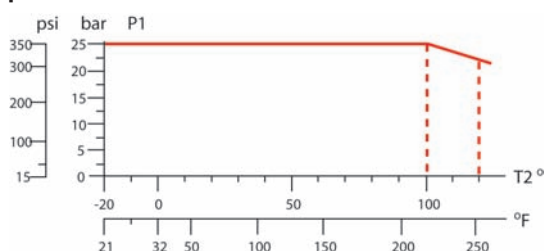

Graph 2

The maximum working pressure in the tank is a function of the interior temperature, as shown in graph 2.

Graph 1

Graph 2

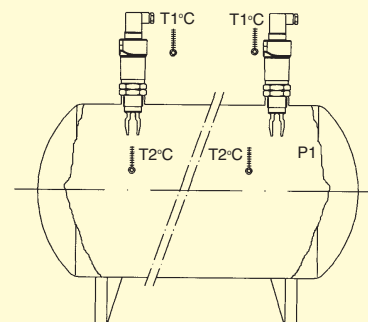

Dimensions

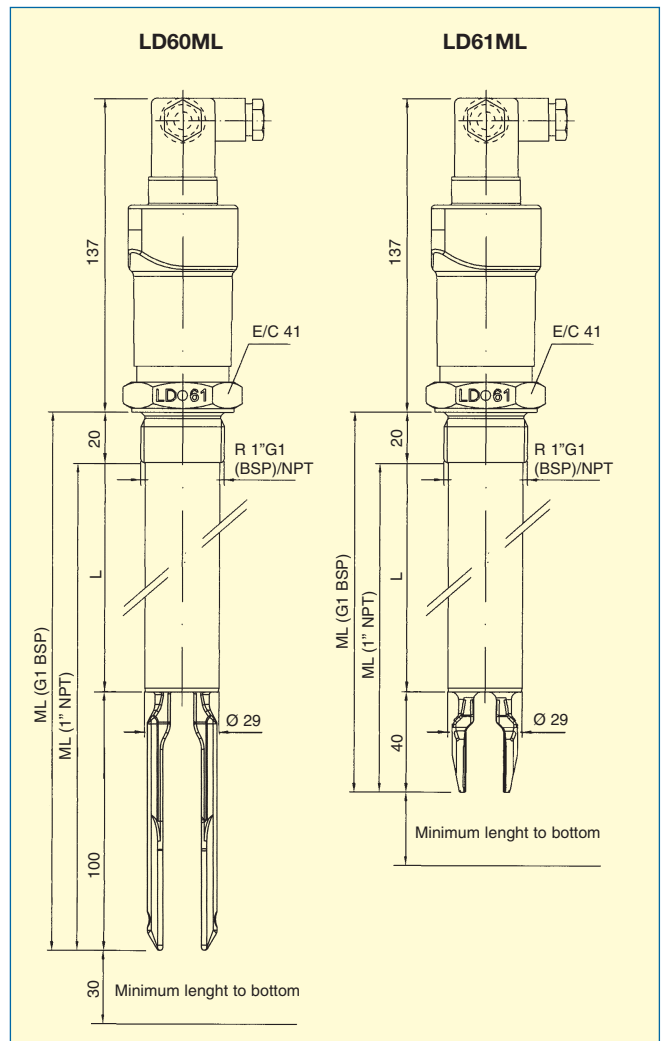
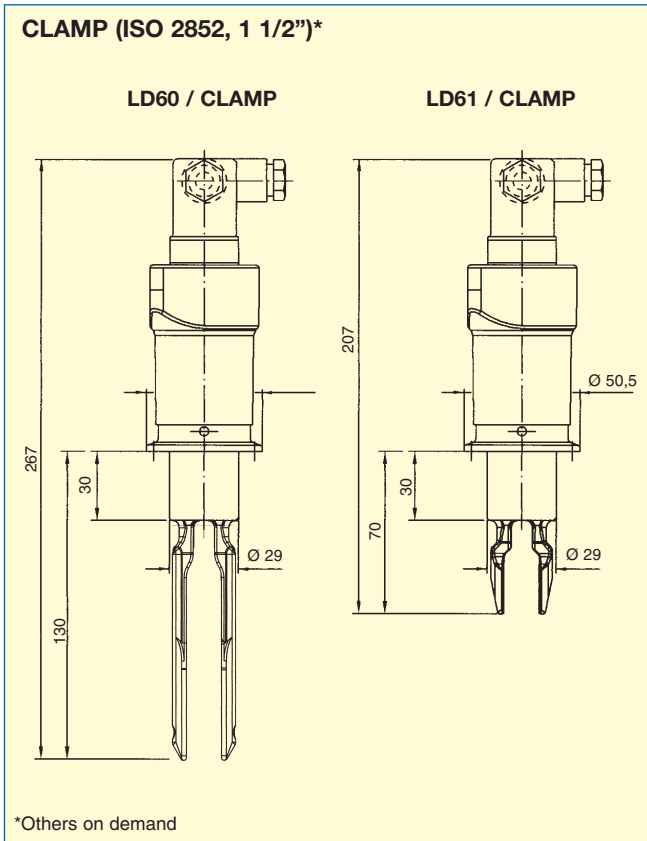
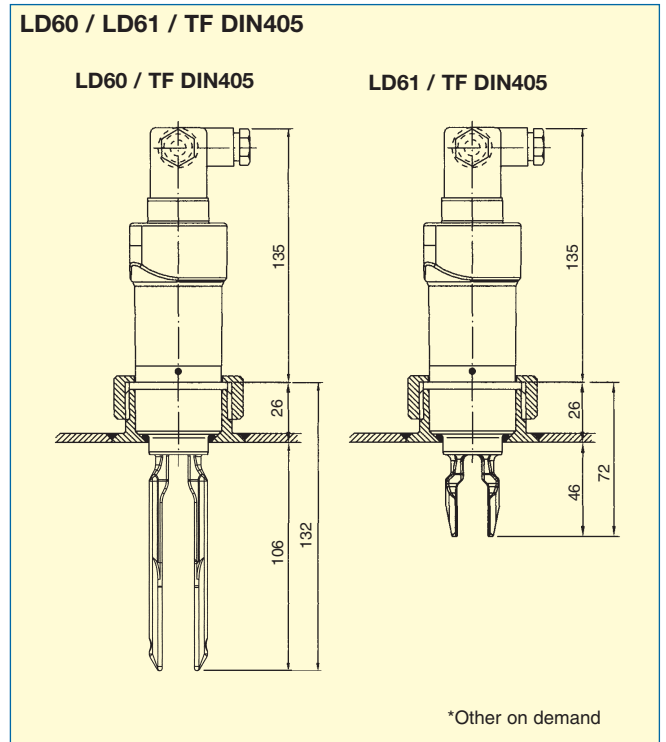
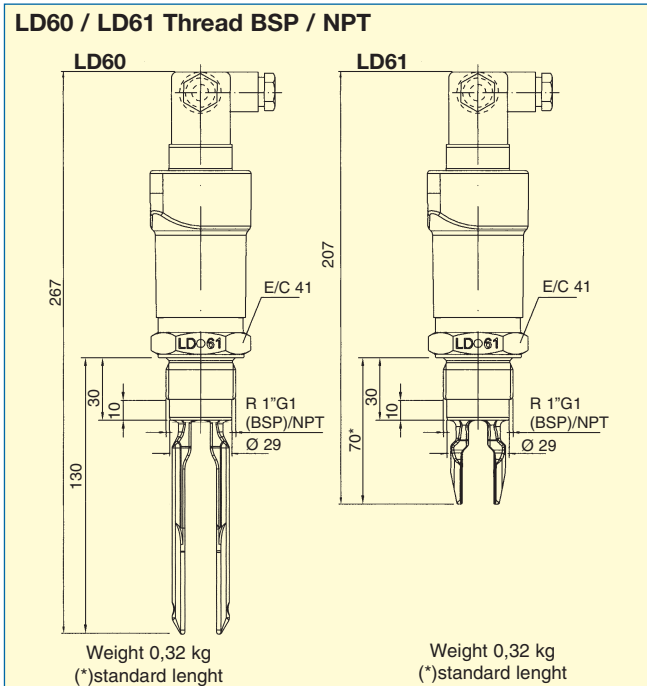

LD60ML / LD61ML (standard length $\pm 1,5$ mm)

ML (G1 BSP) 260 360 560 860 1060 1260 1560 2060

ML (1 NPT) 240 340 540 840 1040 1240 1540 2040

Installation

The optimum mounting position depends on the liquid viscosity and the detection position.

Pos. 1 The installation in the top of the tank is optimal, as also is in **Pos. 1a** for side mounting.

In both positions the liquid can flow easily through the fork allowing correct detection of the liquid level.

Pos. 2 Shows that with couplings with a small diameter (less than DN 50) the fork must be completely outside the neck of the coupling.

La **Pos. 2a** allows the fork to be mounted inside the neck of the coupling, but only when the diameter is greater than DN 50 and the liquid viscosity allows it to flow out fast.

Viscous liquids

Pos. 3 & 3a require a minimum distance that insures a fast flow of the liquid to free the fork.

D minimum = 50 mm (2")

Pipes

Pos. 4

To the partially filling of horizontal pipes, the detector length must be carefully chosen (Pos. 4.1)

For the control of liquid presence in pipes, for example in pump protection, the detector should be mounted in a vertical section with rising flow (Pos. 4.2). Care must be taken in choosing the detector length to avoid contact with the pipe.

The minimum recommended DN is DN 50 (Pos. 4.3).

The maximum recommended velocity is 5m/s for liquids of 1 g/cm³ and 1 mPa·s (consults for other working conditions)

Note: The tines must be aligned with the pipes axis.

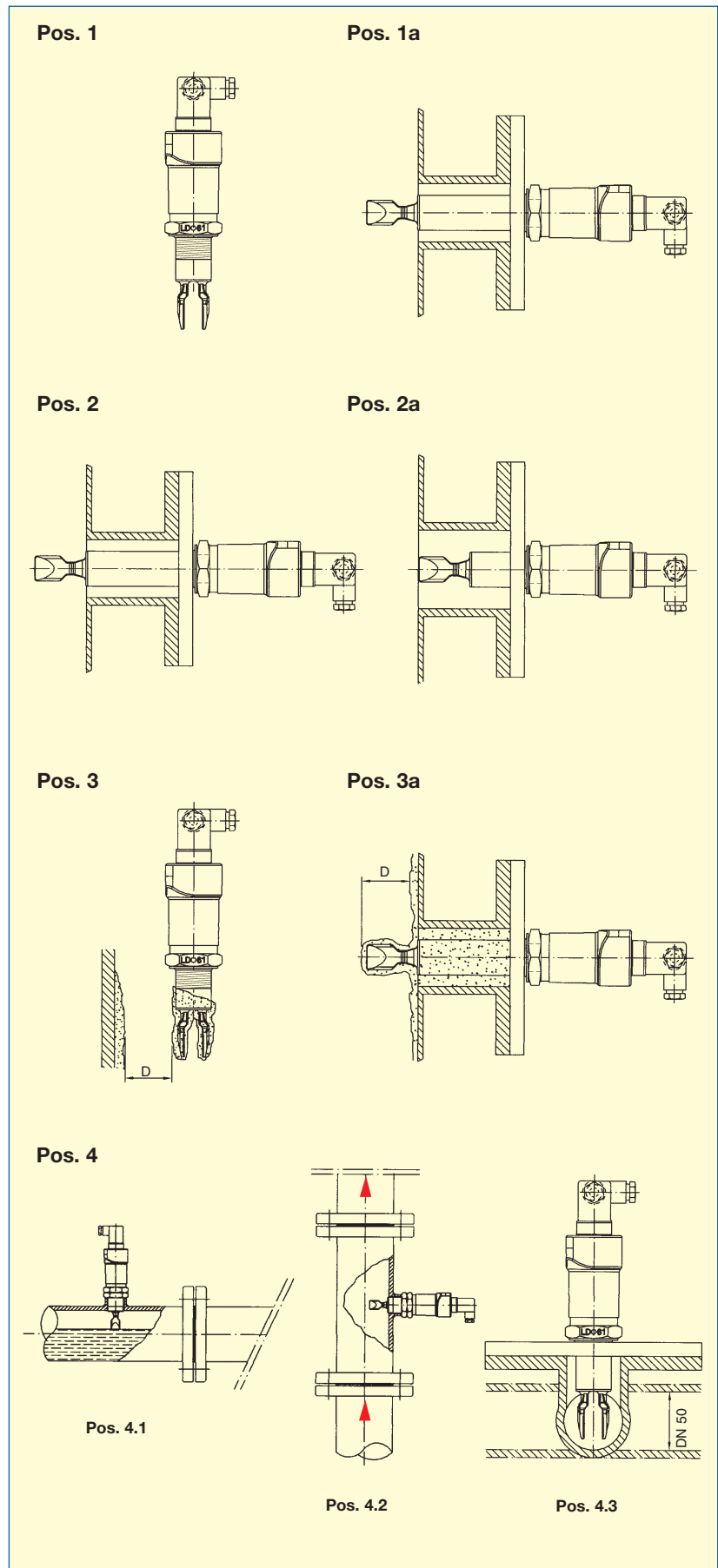

Installation

High temperatures in the tank may require thermal insulation. The LD61 can be supplied with required extra length. The standard extra length is 150 mm (**fig. 1**)

fig. 1

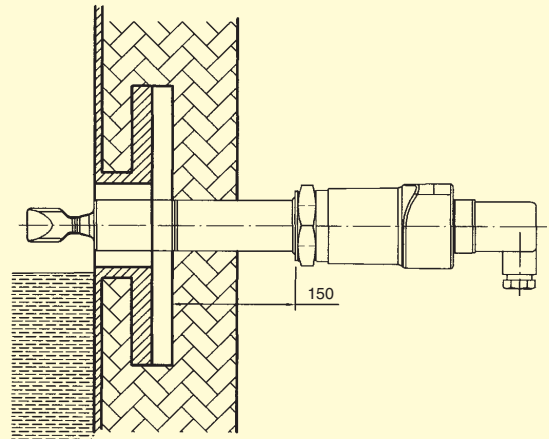

Plumbing

The mounting position of the level detector should not coincide with the point at which liquid falls in the tank (**fig. 2**)

If during the filling of the tank strong waves are produced, the level detector must be protected.

fig. 2

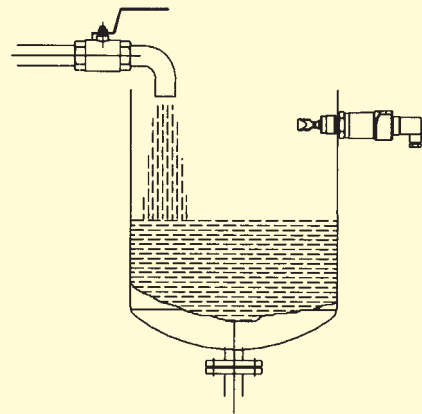

Transport

When controlling levels in moving tanks, a guide pipe should be mounted, with a PTFE pushing at the lower end to avoid vibrations that could effect the level detector (**fig. 3**)

fig. 3

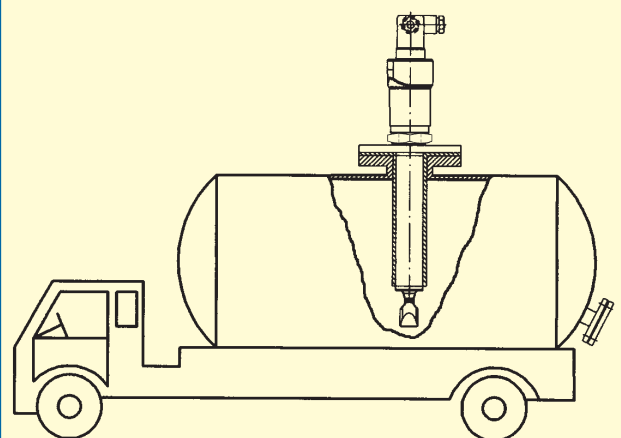

LD61-ML001

Accessories

The LD61 can be supplied with a sliding system to adjust the height of the different maximum or minimum detection points that may be required in different processes in closed tanks.

The stuffing box supplied is fitted with a PTFE gland.

Example

The level differential C between maximum and minimum = 100 mm.

In this case length $L1$ (300 mm) is the minimum level.

The length LS is the maximum level (200 mm).

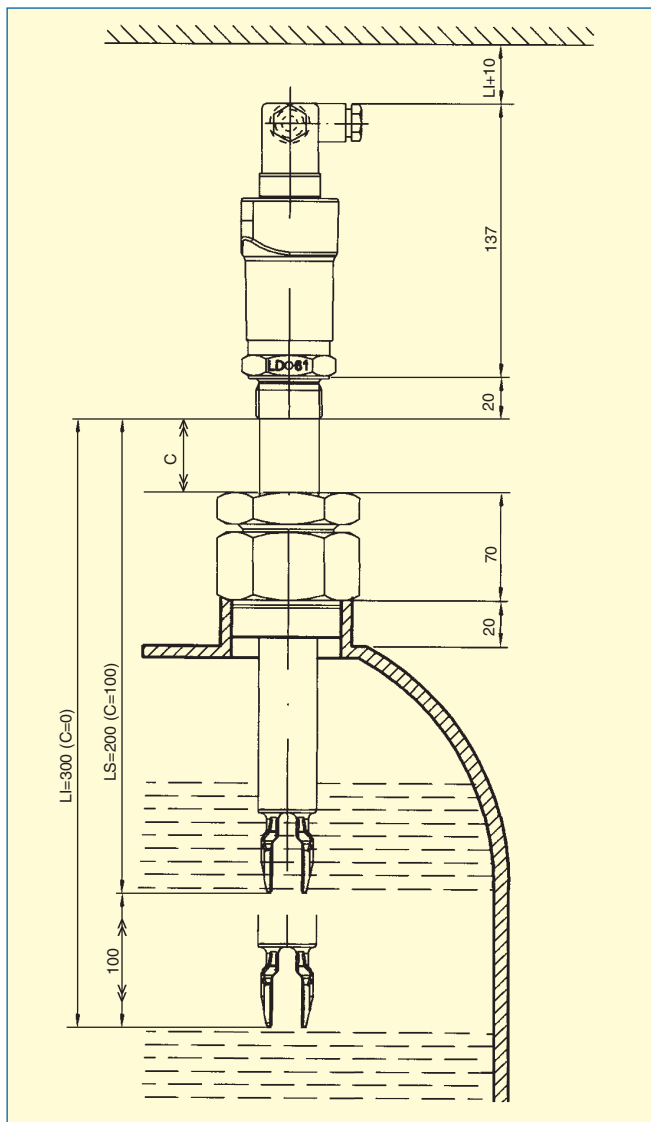

Control of tanks and tanks with agitation

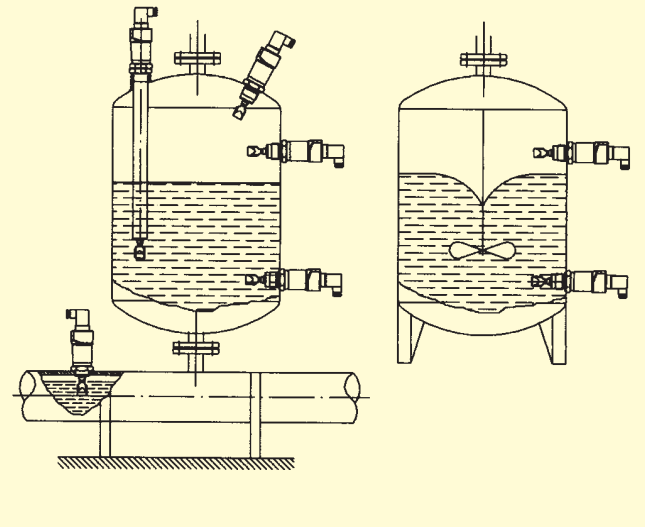

In tanks with agitators, the LD61ML detector must be protected against the force of the rotating liquid in their whole length.

Dosing tanks

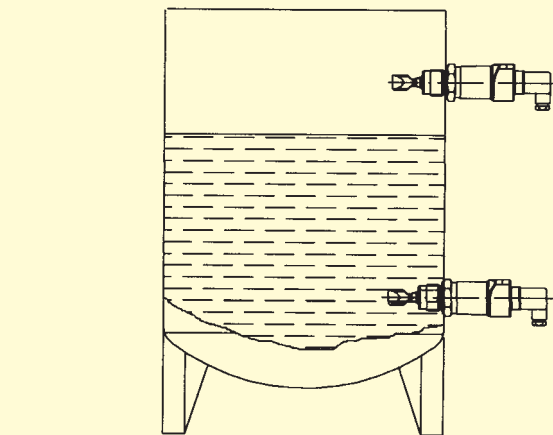

We are at your service, please consult us.
TECFLUID develops and manufactures instruments for gases and liquids, using the most advanced techniques.
Request information by telephone nº: +34 93 372 45 11